

Quantify qDimmer

3 Channel Dimmer

PN01-A033-02

INSTALLATION GUIDE

Product Description

The Quantify Dimmer works with standard AC cabling techniques and can control up to three 240V channels, with a maximum total capacity of 450W. It offers dimming and non-dimming control, and is compatible with a variety of LED, halogen and incandescent load types. All electrical, policy and advanced living experience settings are fully configurable using the Quantify software.

Safety Information

⚠️ ⚠️ DANGER: Electrical Shock Hazard. The supply circuit must be turned off, locked and tagged before installing the qDimmer, or working on loads connected to a qDimmer (e.g. changing light bulbs). Voltage isolation is not provided by the qDevice wall switch. Hazardous voltages exist at terminals L1 to L3, even if the device is in "off" state.

⚠️ WARNING: Do Not Megger Test. Megger testing will damage the Dimmer and will void warranty.

IMPORTANT: This Device MUST only be connected to a circuit protected by a Residual Current Device (RCD) or a Circuit Breaker of 16A capacity or less.

IMPORTANT: This Device is NOT suitable for use in any situation or installation where the failure of the device or any part thereof may result in the loss of life or personal injury.

Compatible Load Types

Load Type	Max. load/channel	Notes
Switched (non-dimmable)	275W	Bathroom extraction fans, non-dimmable LED
Phase dimmable	150W	LED, LV Halogen, Incandescent, Halogen (up to 150w), Fluorescent with electronic ballasts

IMPORTANT: Don't exceed 450W total load on the device. Overloading may result in it automatically switching off one or more loads.

IMPORTANT: Don't connect loads on different phases to the same device.

IMPORTANT: Don't mix load types on any single channel.

Incompatible Load Types

IMPORTANT: Incompatible load types apply to dimmed loads only.

IMPORTANT: There should not be another switch between the device and the load.

The device is designed to operate with a variety of LED and Incandescent lights. This device is protected with both a thermal fuse and load fuse on each channel. Overloading the device on any channel will render the channel inoperable and, in instances of severe overload, may render the entire device inoperable. Loads with a high start-up current (inrush) should be avoided and will cause permanent damage to the device.

Examples of high start-up current devices include:

- Switch Mode Power supplies with large input capacitors.
- HPS lighting
- Metal halide lighting

Other unsuitable devices:

- Fluorescent lighting with iron core ballasts and starters
- Electric motors
- Ceiling fans

Installation Instructions

IMPORTANT: Installation of the qDimmer must be carried out by a qualified electrician and in accordance with local authority rules and regulations. The place of installation should ideally be indoors and protected from extremes of temperature and water ingress.

IMPORTANT: qDimmers must not be wired in series.

IMPORTANT: Strip back 8mm of insulation and terminate tightly under terminating screw. Ensure correct terminals are used.

Dimmer Installation

The Dimmer can be installed into plaster board with a C-Clip or mounted into brick/timber with a standard wall box.

- 1 Screw the Dimmer firmly to the wall without over-tightening the screws. The top of the screw head must be lower than the plastic.
- 2 Ensure that the screws are electrically isolated and cannot expose users to AC power.

Wiring Instructions

⚠ WARNING: All connected loads must be on the same phase.

IMPORTANT: Channel wiring and button mapping best practices regarding network failure:

Quantify recommends to wire the L1 channel to the light in close proximity to the qDevice's installation location. Additionally button-1 (top left on Touch Panel) should be mapped to the L1 channel to ensure that in the event of network failure a light in close proximity is always available to the user.

Standard Wiring (Typical L1-L3)

In the Standard Wiring example (Figure 1), the active and neutral wire are connected to the device as shown. L1-L3 channels are connected to the active input of each attached load.

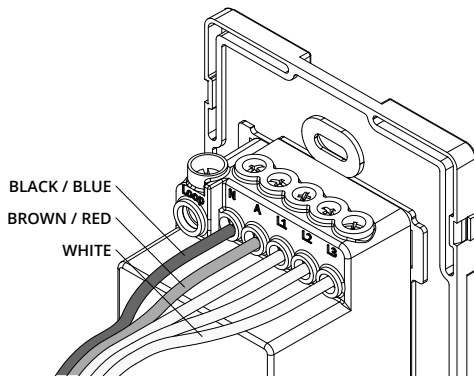

Figure 1: Standard Wiring
(Typical L1-L3 wiring, dedicated neutral)

Note: A single permanent active to the Dimmer is all that is permitted. A single neutral is all that is required.

Slide-in Feature Card Installation

IMPORTANT: Use only Quantify Technology Feature Cards, inserted with arrows in the correct alignment.

Insert the Feature Card into the slot on the Dimmer wall panel, as shown in the illustration. Align the arrow on the front of the Dimmer with the arrow on the Feature Card pull-tab to ensure the correct orientation.

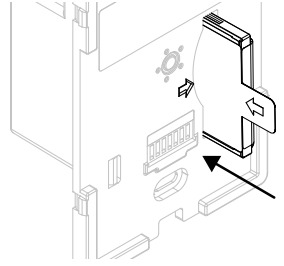

To remove the Feature Card, pull firmly on the protruding tab.

Clip-on Touch Panel Installation and Removal

IMPORTANT: The spring connectors on the Touch Panel must align with the contacts on the Dimmer wall plate. Attaching the Touch Panel upside down may cause damage to the Touch Panel or Dimmer.

- 1 Align the left side of the Touch Panel with the left side of the Dimmer wall plate and clip the Touch Panel in position. The LED lights will light up for 2 seconds and the haptic motor will spin up.

IMPORTANT: Remove the Touch Panel using a soft plastic pry tool.

- 2 Insert the flat end of the tool between wall and the Touch Panel frame on the right hand side and carefully unclip the Panel from the Dimmer wall frame.

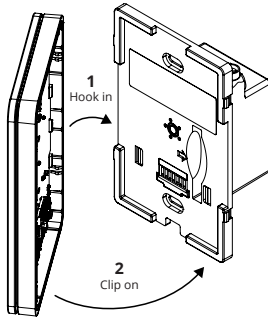

1 Touch Panel installation

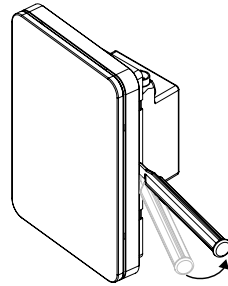

2 Touch Panel removal

Setup and Commissioning

IMPORTANT: The installed qDimmer needs to be commissioned with the qCommission App, available from the Apple App store.

Out of the box, the Dimmer can switch the L1-L3 on and off. Setting up dimming and configuring the Wi-Fi requires the free-to-use qCommission app, available from the Apple App Store.

Operation Instructions

IMPORTANT: A qDimmer that is not commissioned can only switch local channels L1-L3.

A commissioned and networked qDimmer can control any local loads, as well as any remote loads controlled by other qDevices that are part of the same network, as specified in the Living Experience configuration. Living Experiences include single service control, grouped services and scenes. The system can be controlled from the Touch Panels, the qLiving App or by Voice Assistant.

Additional Help

IMPORTANT: We constantly work to improve our products, and document any changes or updates here: www.quantifytechnology.com/product-documentation



qCommission App



Product Updates

Specifications

Operating Voltage AC	220-240V		
Frequency	50Hz		
Max. Total Capacity	450W		
Capacity/Dimming/Channel	150W	Ideal load (derating depending on load type)	
Capacity/Switch/Channel	275W	On a single channel only per device	
Wiring Configuration	Standard wiring	Dedicated neutral	
Minimum Load	Standard wiring	5W	
Output Channels	1, 2 or 3		
Dimmable	Yes		
Over-current Protection	Yes	Each channel 1x2A fuse and 1x115°C thermal fuse 1x Power supply fuse 2A	
Current Monitoring	Yes	Accurate to 5% at 25°C	
Operating Temperature	0°C to 40°C		
Operating Humidity Range	10 to 85% RH		
Mounting Cavity	80mm	54mm	45mm
Mounting Centres	84mm		
IP rating	IP20		
Safety Compliance/ EMC Compliance	IEC 60669-1	IEC 60669-2-1 (Relevant sections)	

Warranty

GENERAL WARRANTY ON PRODUCTS

LIMITED WARRANTY

Quantify offers a warranty of 24 months (Warranty Term) from the date of delivery of the Quantify products for all defects in materials or workmanship for any products supplied to the Client. Where a product supplied to the Client is defective within the Warranty Term, Quantify will either repair or replace those products at its discretion. Refurbished parts may be used to repair the Products. Replacement of the Product or a part does not extend or restart the Warranty Term. If a Product presented for repair is capable of retaining user-generated data, the Reseller acknowledges that repair of the Product may result in loss of the data. Quantify may offer different delivery methods for warranty service, including, but not limited to, parts and product dispatches, mail-in service and onsite/in-home service or as otherwise agreed between the Client and Quantify in writing. Quantify will cover any costs to get the repaired/tested/replaced Products back to the Client. Any Products being sent in for warranty should be sent with all parts unless otherwise advised by one of Quantify's staff.

GENERAL EXCLUSIONS AND LIMITATIONS

The Warranty will not apply:

- to a Product which has not been installed, operated, maintained or used in accordance with the manufacturer's instructions or specifications provided with the Product;
 - to a Product where the factory-applied serial number has been altered or removed;
 - to a Product where the Product is, or has been damaged, has malfunctioned or failed due to alterations, accident, misuse, abuse, fire, liquid spillage, mis-adjustment of customer controls, used on an incorrect voltage, power surges and dips, thunderstorm activity, acts of God, voltage supply problems, tampering or unauthorised repairs by any persons other than by Quantify, the operation of a computer virus of any kind, exposure to abnormally corrosive conditions or entry by any insect, vermin or foreign object in the Product, normal wear and tear, or use of parts and components not supplied or intended for use with Quantify's Products;
 - to third-party products or software that are bundled or provided with the Services; and
 - in relation to results to be obtained from the products or Software.
- Full terms and conditions including Warranty Terms can be found on Quantify's website.

Technical Specifications for products with future release dates are subject to change and should not be relied upon.

Quantify Technology Pty Ltd

Suites 2 & 3, 6 Brodie Hall Drive, Technology Park, Bentley, WA, 6102

+61 (8) 6254 0200

info@quantifytechnology.com

www.quantifytechnology.com